



FRES  
SPORT



*No limits to inspiration.*



**EURO SEATING INTERNATIONAL**

Polígono Industrial El RAM, No. 11  
C.P. 26280 Ezcaray  
La Rioja, España

Tel. +34 941 427 450  
941 427 452

euroseating@euroseating.com  
www.euroseating.com



Carretera Tlajomulco, San Isidro Mazatepec No.615 F  
CP 45640, Santa Cruz de las Flores,  
Jalisco, México

Tel. (+52) 33 37 96 01 56  
33 37 96 52 82  
33 36 12 17 50

euro.seating@euroseating-america.com  
www.euroseating-america.com

Seats for Cinema, Theater, Auditorium, Sport venues, Stadium, Telescopic bleacher, Conference room  
Butacas para Cine, Teatro, Auditorio, Congresos, Estadios, Instalaciones Deportivas, Graderíos Telescópicos, Sala de Conferencias



## Seat featuring sleek and soft lines in every contour,

ergonomically designed without using metal in its structure or sides, backrest made out of one single ergonomic piece using the Fresh avant-garde design, which encourages the transpiration and circulation of air, automatic lifting of the seat in a padded and upholstered finish.

## Ideal for Sport areas, Stadium any Arenas.

Its careful design is focused on comfort over long periods of time, its design and materials offer durability and maintenance free seating.

## Butaca de líneas depuradas y suaves en todos sus contornos,

de formas ergonómicas sin la utilización de metal en estructura o laterales, respaldo fabricado en una sola pieza ergonómica mediante el diseño vanguardista Fresh, que favorece la transpiración y circulación de aire, asiento de elevación automática en acabado acolchado y tapizado.

## Perfecta para Áreas deportivas, Estadios y Arenas.

Su cuidadoso diseño favorece el confort por periodos prolongados. Su diseño y materiales facilitan la durabilidad así como la ausencia de mantenimiento.

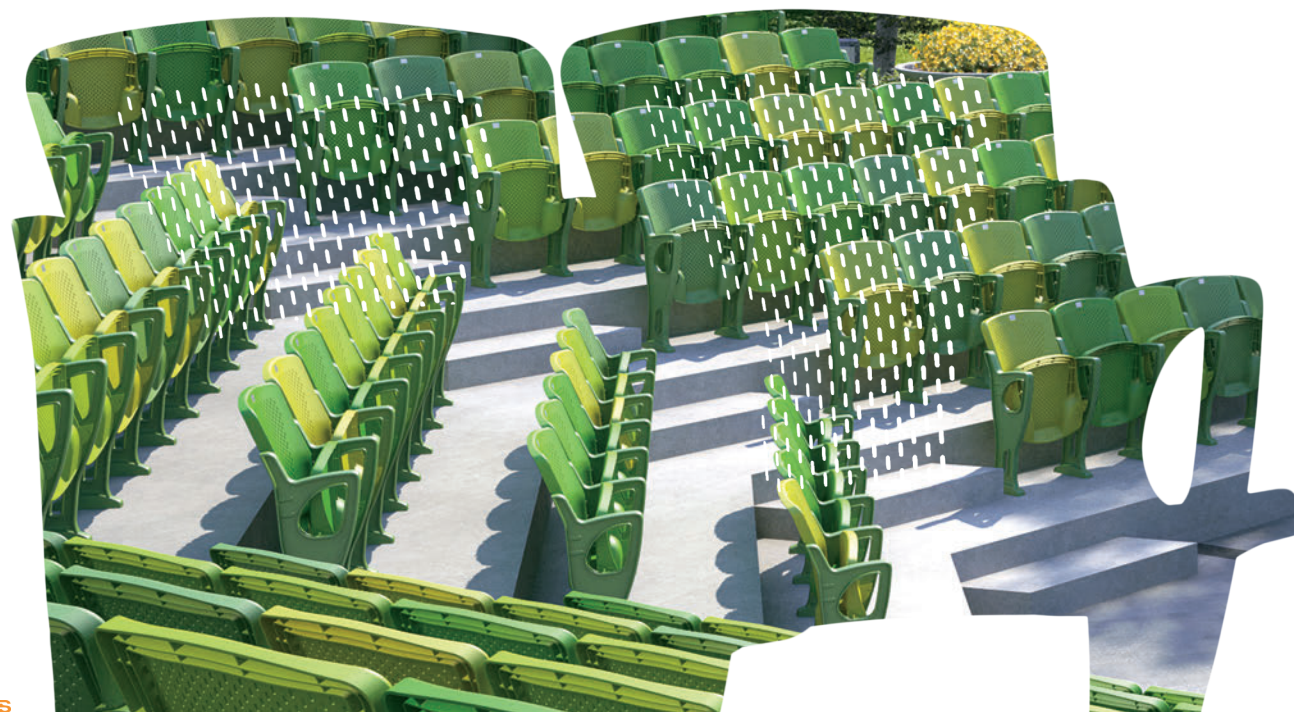

FRESH  
SPORT



# FRESH SPORT

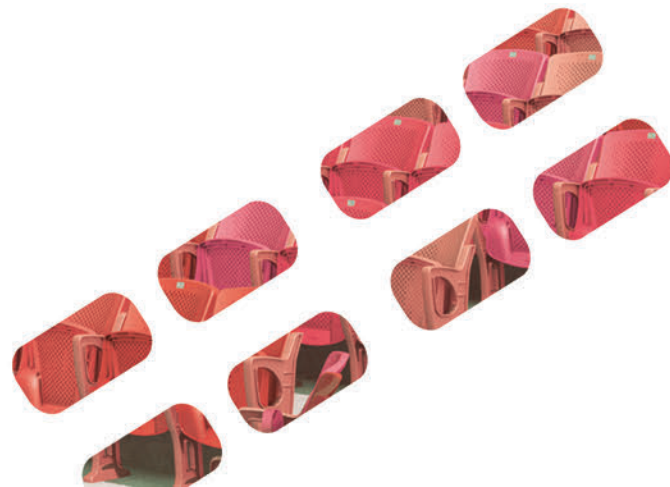

FRESH

FRESH AT PV

FRESH AT FG

# FRES

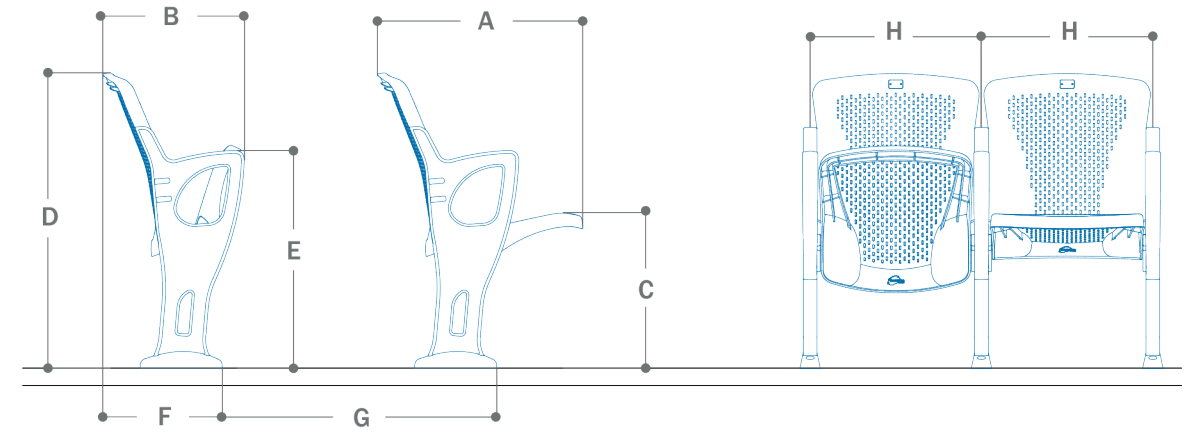

DIMENSIONES DE BUTACA	
A	600 mm (23 5/8")
B	400 mm (16 1/4")
C	450 mm (17 3/4")
D	860 mm (33 7/8")
E	635 mm (25")
F	350 mm (13 3/4")
G	Huella Mínima recomendada 800 mm (31 1/2")
H	Min. 500 mm (19 5/8") / Max. 550 mm (21 5/8") * Medidas mas amplias Consultar

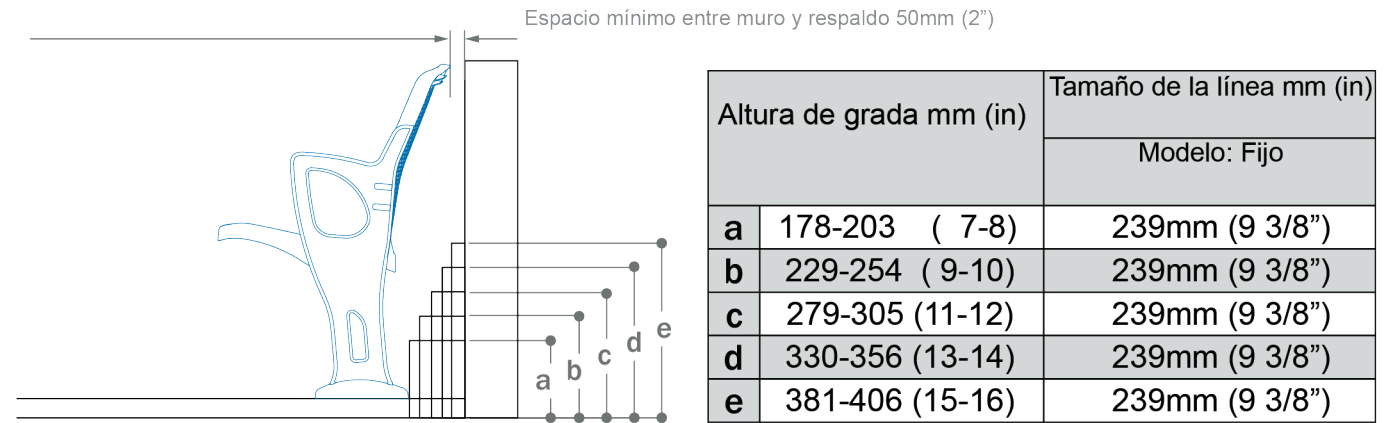

Tamaño de la línea: Distancia tomada del barreno delantero de la pata a la grada

straight row filas rectas □□□□□□	disposition in curve disposicion en curva □□□□□□	sets of single or several seats arreglos de una o varias butacas □ □□ □□□	flat floor piso plano	inclined floor piso inclinado	floor in stand piso en gradería
✓	✓	✓	✓	✓	✓

- Mobile model seat available with skid (the seat is not fixed on the surface)  
- Modelo Móvil con patín disponible (la butaca no se fija en el suelo).

Curve row  
Check radio  
Fila curva  
Consultar radio

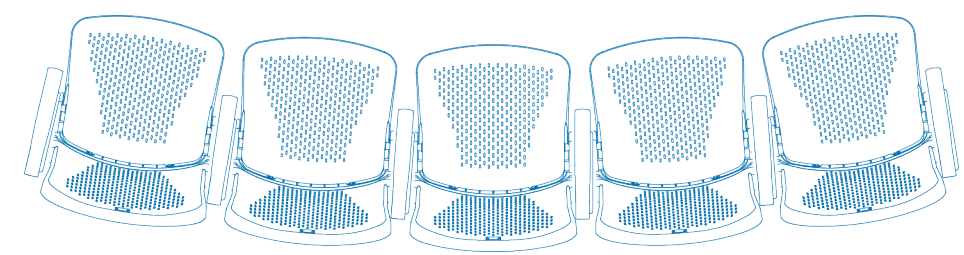

# FRES

FG

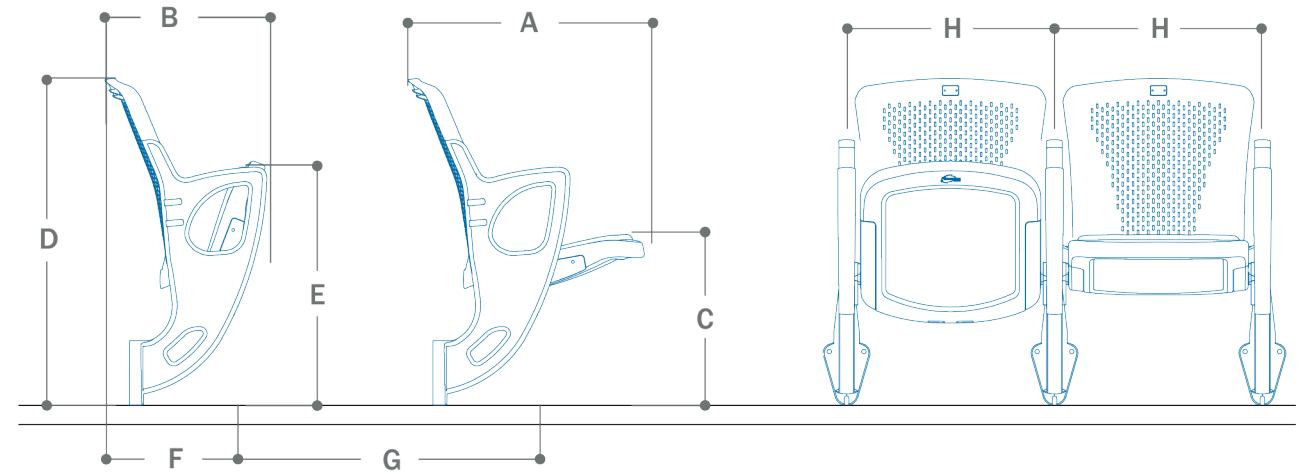

ARMCHAIR DIMENSIONS / DIMENSIONES DE BUTACA	
<b>A</b>	600 mm (23 5/8")
<b>B</b>	400 mm (16 1/4")
<b>C</b>	460 mm (18 1/8")
<b>D</b>	860 mm (33 7/8")
<b>E</b>	635 mm (25")
<b>F</b>	350 mm (13 3/4")
<b>G</b>	Minimum back to back spacing recommended 800 mm (31 1/2") / Huella Mínima recomendada 800 mm (31 1/2")
<b>H</b>	Min. 500 mm (19 5/8") / Max. 550 mm (21 5/8") *More extensive measures Consult / Medidas más amplias Consultar

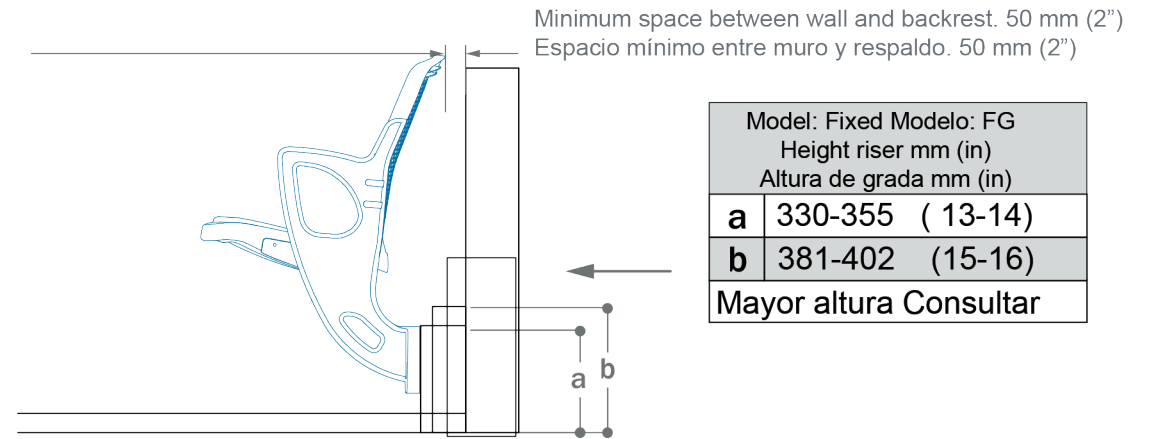

straight row filas rectas	disposition in curve disposicion en curva	sets of single or several seats arreglos de una o varias butacas	flat floor piso plano	inclined floor piso inclinado	floor in stand piso en gradería
□□□□□□	□□□□□□	□ □ □ □	—	—	—
✓	✓	✓	✓	✓	✓

· Mobile model seat available with skid (the seat is not fixed on the surface)  
· Modelo Móvil con patín disponible (la butaca no se fija en el suelo).

Curve row  
Check radio  
Fila curva  
Consultar radio

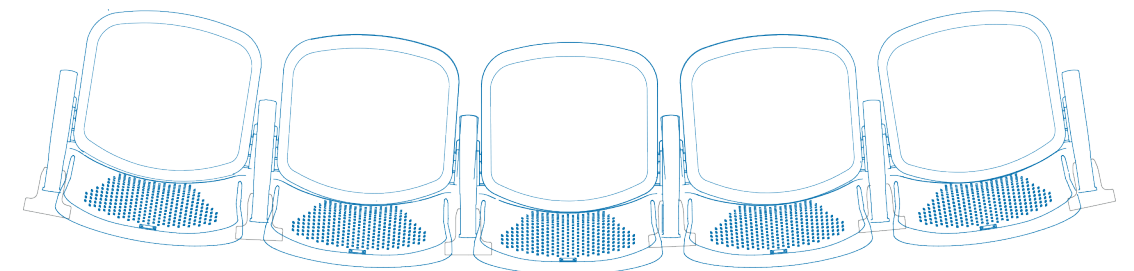

# FRESH



1



## BACKREST:

The structure of the backrest consists of a high impact polypropylene body, ergonomically shaped and with the innovative Fresh design, which maximizes comfort during use by allowing for full transpiration and aiding the user's correct posture.

## RESPALDO:

La estructura del respaldo realizada por un cuerpo de polipropileno de alto impacto, de forma ergonómica y con el novedoso diseño Fresh, que maximiza el confort durante el uso al permitir la total transpiración y ayudar a una correcta postura del usuario.

2



## SEAT:

The seat structure consists of a high impact polypropylene body, ergonomically shaped and with the innovative Fresh design, which maximizes comfort during use by allowing for full transpiration and aiding the user's correct posture. Optional seat in smooth finish or with fabric and padded with fabric for outdoor environments.

## ASIENTO:

La estructura del asiento realizada por un cuerpo de polipropileno de alto impacto, de forma ergonómica y con el novedoso diseño Fresh, que maximiza el confort durante el uso al permitir la total transpiración y ayudar a una correcta postura del usuario. Opcional acabado liso o con tejido y acolchado con tejido para ambientes exteriores

3



## SIDES:

Manufactured in reinforced, high-impact polypropylene, extremely resilient, 40 mm in width, textured across its profile for a pleasant feel. The seat will be fastened by means of screws specific to the constructive section of the material out of which the hall's floor is made and which once it is attached to the floor, is completely hidden, leaving no screws in sight, providing beauty and refined lines at the foot which makes it easy to clean and avoids degradation, oxidation, manipulation and/or deterioration of the screws attaching the chair to the floor. Option of direct fixing to the floor, in cantilever or in rail format.

## LATERAL:

Fabricadas en polipropileno de alto impacto reforzado, extremadamente resistente de 40 mm. de ancho y texturizadas en todo su perfil para un tacto agradable. La fijación se realizará con tornillería específica a la sección constructiva del material del piso de la sala y que una vez sujeta al piso, queda totalmente oculta, evitando dejar tornillería a la vista, aportando belleza y depuradas líneas en el pie que facilitan la limpieza y evitan la degradación, oxidación, manipulación y/o deterioro de la tornillería de fijación al piso. Opción de fijación al piso, en la vertical de la grada o en bancadas.

## OPTIONS / OPCIONES



**CUP HOLDER:** Large capacity optional  
**PORTAVASOS:** Opcional de gran capacidad



**WRITING TABLE:** Optional on the seat side  
**PALETA DE ESCRITURA:** Opcional en lateral de la butaca



**NUMBERING:** Both at each seat, as well as at each row  
**NUMERACIÓN:** Tanto de butaca como de fila



**SEAT:** Fresh finish / Smooth finish / Upholstered finish  
**ASIENTO:** Acabado fresh / Acabado liso / Acabado tapizado



## THE FASTENING:

- Can be made with 2 legs anchored directly to the floor
- Mounted on the vertical of the slipway
- On pallets with a central axis



## FIJACIÓN:

- Puede realizarse en 2 pies de fijación directa al piso
- Fijación en la vertical de la grada
- En bancadas con pie central



## COLORS / COLORES:

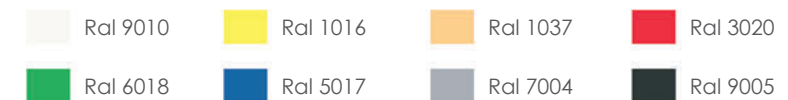

Other colors, consult / Otros colores, consultar.



ISO 9001  
· Quality Certificate  
· Certificado de Calidad



ISO 14001  
· Environment Certificate  
· Certificada y comprometida con el Medio Ambiente



ISO 14006  
· Ecodesign Certificate  
· Certificado Ecodiseño



UNE EN 12727:2001  
· Resistance Certificate  
· Certificado Uso intenso nivel 4



UNE EN 13200-4  
· Resistance to atmospheric agents  
· Stability to light  
· Resistencia a los agentes atmosféricos  
· Estabilidad a la luz



Alfredo Harp Helú Stadium. / MEXICO



Agora Nantes. / FRANCE



Wlokniaz Stadium. / POLAND

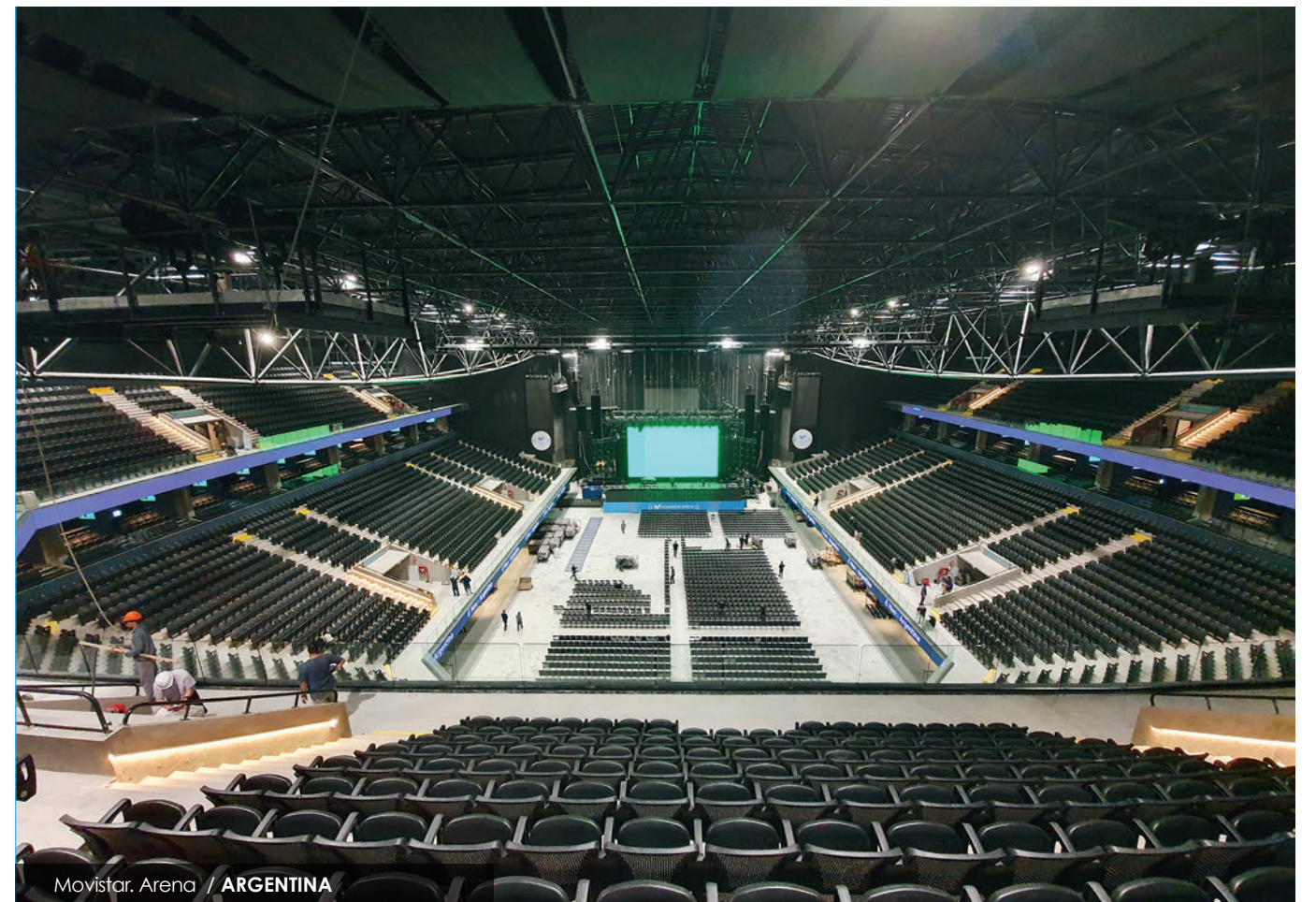

Movistar Arena / ARGENTINA